

MDT1010C2IS-LVDS	1280 x 800	LVDS Interface	TFT Module
Specification			
Version: 1		Date: 16/06/2017	
Revision			
1	14/06/2017	First issue	

Display Features			
Display Size	10.10"		
Resolution	1280 x 800		
Orientation	Landscape		
Appearance	RGB		
Logic Voltage	3.3V		
Interface	LVDS		
Brightness	350 cd/m ²		
Touchscreen	---		
Module Size	240.96 x 155.60 x 3.95mm		
Operating Temperature	-20°C ~ +70°C		
Pinout	40 Way Connector		Box Quantity
Pitch	---		Weight / Display

Display Accessories	
Part Number	Description

Optional Variants	
Appearances	Voltage



General Specifications

	Feature	Spec
Characteristics	Size	10.1 inch
	Resolution	1280(horizontal)*800(Vertical)
	Interface	LVDS
	Connect type	Connector
	Color Depth	16.7M
	Technology type	a-Si
	Display Spec. Pixel pitch (mm)	-
	Pixel Configuration	R.G.B.-Vertical Stripe
	Display Mode	Normally Black
	Driver IC	TBD
	Surface Treatment	HC
Viewing Direction	ALL	
Mechanical	LCM (W x H x D) (mm)	240.96X155.6*3.95
	Active Area(mm)	216.96X135.6
	With /Without TSP	Without TSP
	Weight (g)	TBD
	LED Numbers	36 LEDs (3*12)

Note 1: Viewing direction is follow the data which measured by optics equipment.

Note 2: Requirements on Environmental Protection: RoHS

Note 3: LCM weight tolerance: +/- 5%



Input/Output Terminals

Pin No.	Symbol	Description	Remarks
1	VCOM	Common Voltage	
2, 3	VDD	Power Supply	
4	NC	Not connection	
5	NC	Receive for BIST	BIST function enable
6	NC	Not connection	
7	GND	Ground	
8	Rxin0-	(-)Differential Data Input	R0-R5, G0
9	Rxin0+	(+)Differential Data Input	
10	GND	Ground	
11	Rxin1-	(-)Differential Data Input	
12	Rxin1+	(+)Differential Data Input	
13	GND	Ground	
14	Rxin2-	(-)Differential Data Input	G1-G5, B0, B1
15	Rxin2+	(+)Differential Data Input	
16	GND	Ground	
17	FXCLK-	(-)Differential Clock Input	B2-B5, HS, VS, DE
18	FXCLK+	(+)Differential Clock Input	
19	GND	Ground	
20	Rxin3-	(-)Differential Data Input	
21	Rxin3+	(+)Differential Data Input	
22	GND	Ground	
23, 24	NC	Not connection	
25	GND	Ground	
26-28	NC	Not connection	
29	AVDD	Analog Power Supply	
30	GND	Ground	
31, 32	LED-	LED Cathode	
33, 34	NC	Not connection	
35	VGL	TFT Gate Off Voltage	
36, 37	NC	Not connection	
38	VGH	TFT Gate On Voltage	
39, 40	LED+	LED Anode	

Absolute Maximum Ratings

Item	Symbol	Min	Max	Unit	Condition
Supply Voltage	VDD	-0.3	3.6	V	Typ.=3.3V
Supply V_LED voltage	V_LED	27	33	V	
Input Signal		-0.3	2.7	v	LVDS signals
Operating Temperature	TOP	-20	+65	deg. C	(Note 3)
Storage Temperature	TST	-40	+85	deg. C	(Note 3)
Vibration	-	-	1.5G 10~500Hz	G Hz	30min for X, Y, Z axis
Shock	-	-	220 2	G ms	Half sign wave
LED Current	I_LED	-	80	mA	per LED

Note:

- (1) Maximum Wet-Bulb should be 39 degree C. No condensation.
- (2) When you apply the LCD module for OA system. Please make sure to keep the temperature of LCD module is less than 60°C.
- (3) Storage /Operating temperature.

Relative Humidity(%RH)

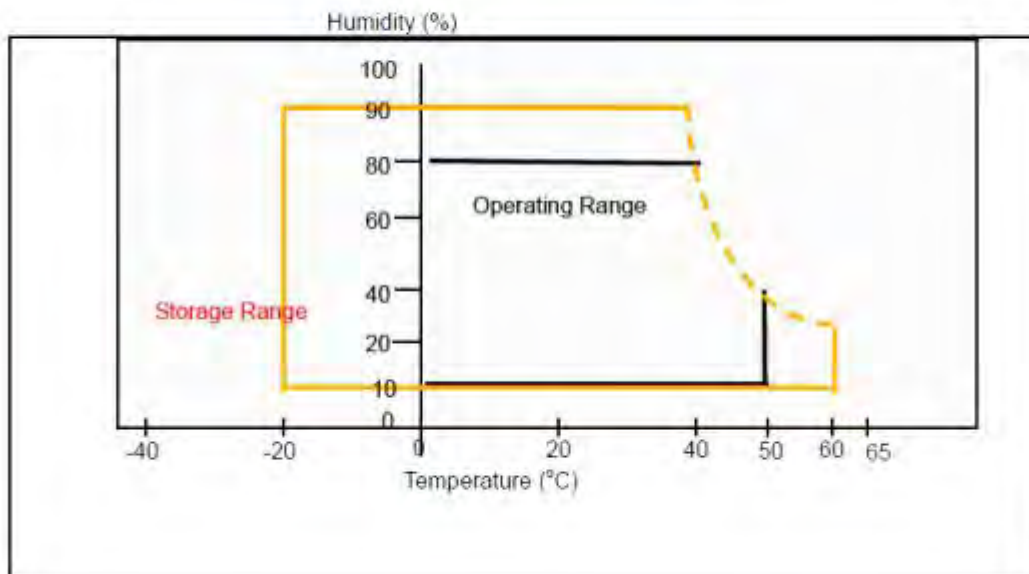

Electrical Characteristics

LVDS Receiver

5.1 Signal Electrical Characteristics for LVDS Receiver

The built-in LVDS receiver is compatible with (ANSI/TIA/TIA-644) standard.

Table 6 LVDS Receiver Electrical Characteristics

Parameter	Symbol	Min.	Typ.	Max.	Unit	Conditions
LVDS Input High Threshold	V_{th}	-	-	+100	mV	$V_{cm/lvds}=1.2V$
LVDS Input Low Threshold	V_{tl}	-100	-	-	mV	$V_{cm/lvds}=1.2V$
Magnitude Differential Input Voltage	$ V_{id} $	100	-	600	mV	
Common Mode Voltage	V_{cm}	1.0	1.2	1.4	V	
Common Mode Voltage Offset	ΔV_{cm}	-	-	50	mV	

Note:

- A. Input signals shall be low or Hi-Z state when VDD is
- B. All electrical characteristics for LVDS signal are defined the interface connector of LCD.

Note: All values are at VDD=3.3V, Ta=25 degree C.

Figure 7 Voltage Definitions

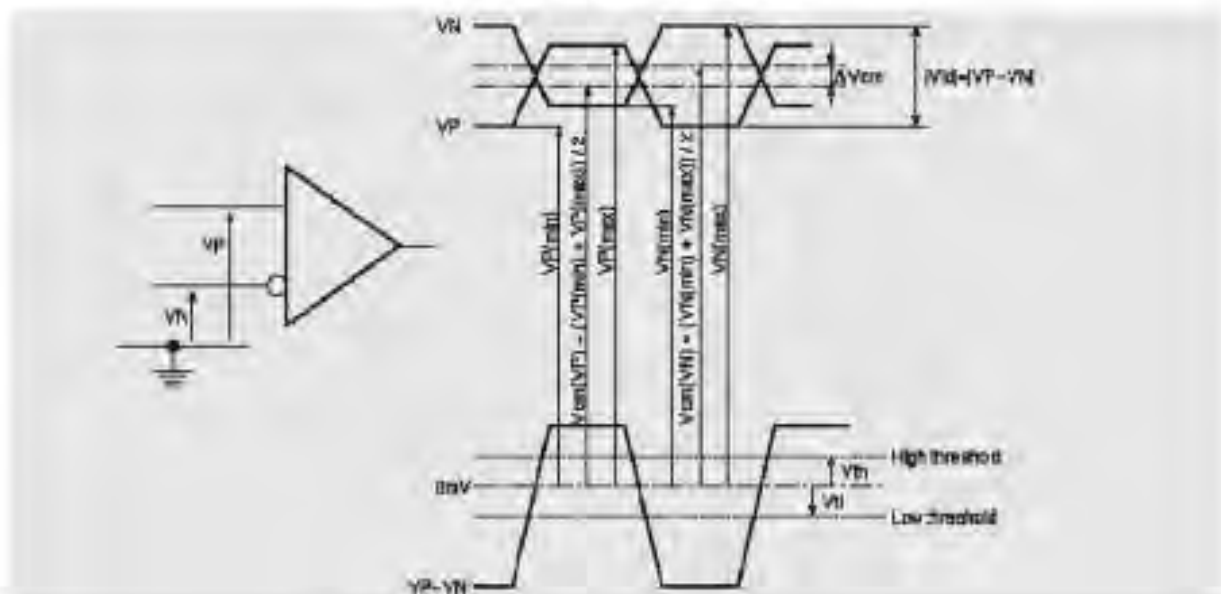

Figure 8 Measurement System

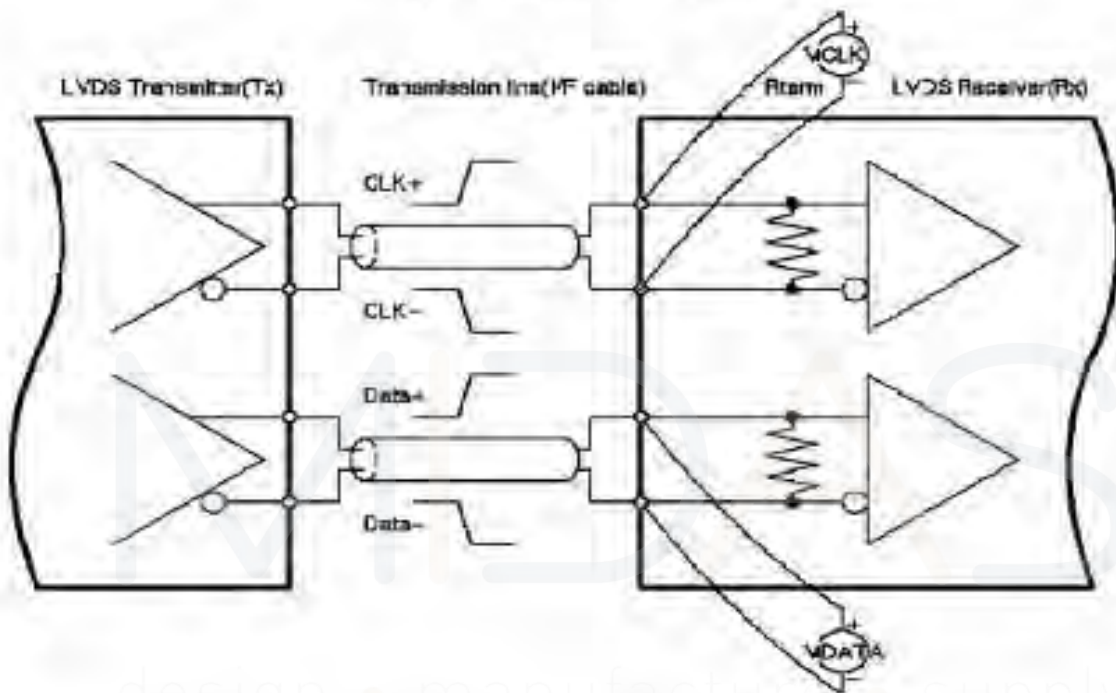
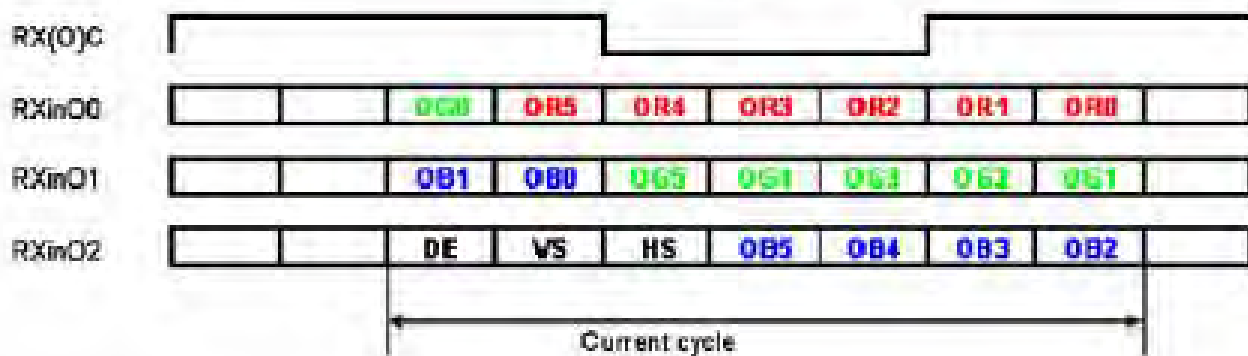

Figure 9 Data mapping



5.2 LVDS Receiver Internal Circuit

Figure 10 LVDS Receiver Internal Circuit shows the internal block diagram of the LVDS receiver. This LCD module equips termination resistors for LVDS link.

Figure 10 LVDS Receiver Internal Circuit

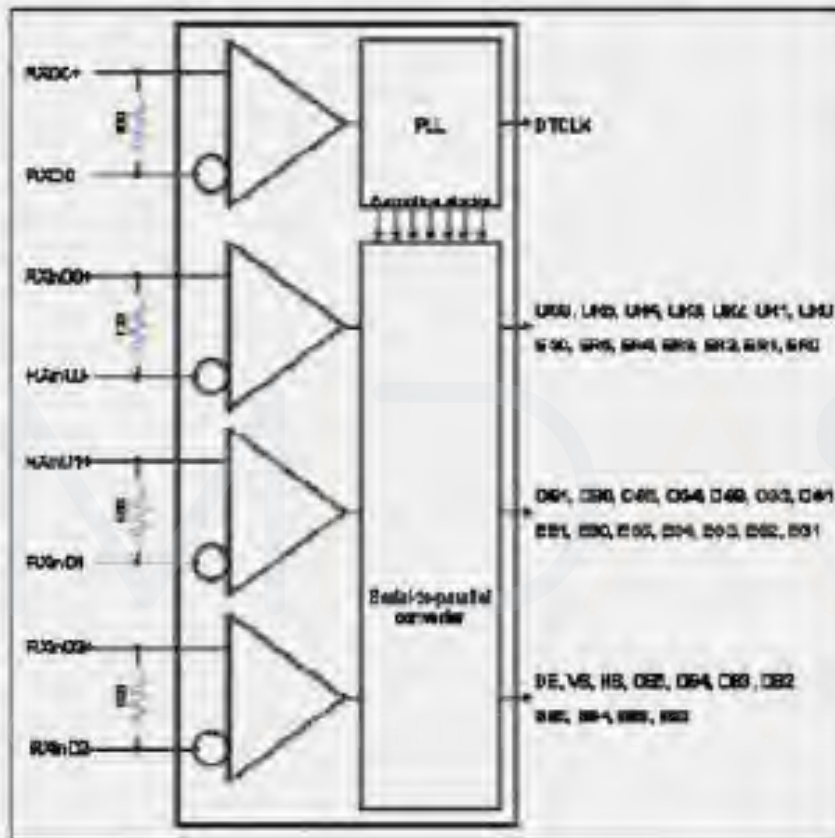

Typical Operation Conditions

Item	Symbol	MIN	Typ	MAX	Unit	Remark
Digital Supply Voltage	DVDD	3	3.3	3.6	V	
TFT Gate on Voltage	VGH	20	21	22	V	
TFT Gate off Voltage	VGL	-6.0	-5.5	-5.0	V	
Analog power Supply Voltage	AVDD	3.6	3.8	4	V	
TFT Common electrode Voltage	VCOM	10.65	10.85	11.05	V	

Interface Timings

Timing Characteristics

Signal	Item	Symbol	Min	Type	Max	Unit
DCLK	Frequency	1/TC	60	65	70	MHz
	Cycle	Tc	16.66	15.38	14.3	ns
DE	Horizontal Period	THd	1280	1280	1280	Tc
	Horizontal Cycle	TH	1310	1330	1560	Tc
		TH_time	19.5	20.46	21.83	ns
	Vertical Period	TVd	800	800	800	Tc
Vertical Cycle	TV	-	812	-	Tc	

Figure 11 Timing Characteristics

36		64	100		65.00	65MHz Main clock
37		19	25			
38		00	0		1280	Hor Active = 1280
39		32	50		50	Hor Blanking = 50
3A		50	80		-	4 bits of Hor. Active + 4 bits of Hor. Blanking
3B		20	32		800	Ver Active = 768
3C		0C	12		12	Ver Blanking = 12
3D		30	48		-	4 bits of Ver. Active + 4 bits of Ver. Blanking
3E	Detailed timing/monitor descriptor #1	0A	10		10	Hor Sync Offset = 10
3F		20	32		32	H Sync Pulse Width = 32
40		36	54		3	V sync Offset = 3 line
41		00	0		6	V Sync Pulse width : 6 line
42		D9	217		217	Horizontal Image Size = 217 mm (Low 8 bits)
43		88	136		136	Vertical Image Size = 136 mm (Low 8 bits)
44		00	0		-	4 bits of Hor Image Size + 4 bits of Ver Image Size
45		00	0		0	Hor Border (pixels)
46		00	0		0	Vertical Border (Lines)
47			19	25		

Note: TES is data enable signal setup time.



Power Consumption

Input power specifications are as follows.

Table 8 Power Consumption

Symbol	Parameter	Min.	Typ.	Max.	Units	Condition
VDD	Logic/LCD Drive Voltage	3.0	3.3	3.6	V	
IDD	VDD Current	--	160	250	mA	All black pattern, 60Hz
PDD	VDD Power	--	0.50	--	W	
Irush	Rush Current	--	--	TBD	A	Note 1
VDDrp	Allowable Logic/LCD Drive Ripple Voltage	--	--	300	[mVp-p]	

Note: 1. Measure Condition

Figure 12 VDD rising time

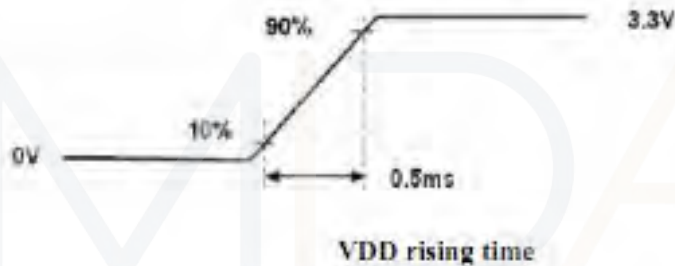

2.VDD Power Dip Condition

Figure 13 VDD Power Dip

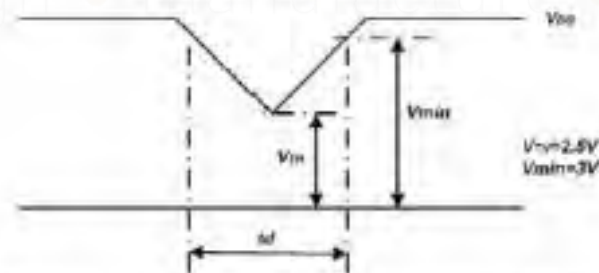

If $V_{TH} < V_{DD} \leq V_{min}$, then $t_d \leq 10ms$; when the voltage return to normal our panel must revive automatically.

Power ON/OFF Sequence

VDD power, interface signals, and lamp on/off sequence are shown in Figure 12. Signals shall be Hi-Z state or low level when VDD is off.

Figure 12 Power Sequence

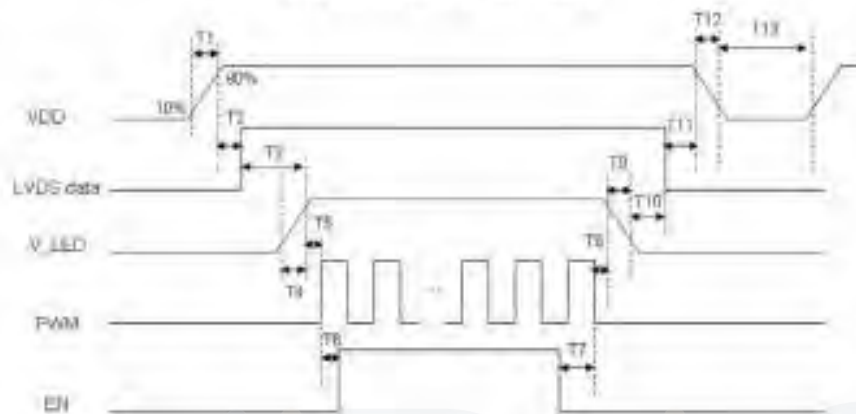

Table 9 Power Sequencing Requirements

Parameter	Symbol	Unit	min	typ	max
VDD Rise Time	T1	ms	0.5	--	10
VDD Good to Signal Valid	T2	ms	30	--	90
Signal Valid to Backlight On	T3	ms	200	--	--
Backlight Power On Time	T4	ms	0.5	--	--
Backlight VDD Good to System PWM On	T5	ms	10	--	--
System PWM ON to Backlight Enable ON (If Have)	T6	ms	10	--	--
Backlight Enable Off to System PWM Off (If Have)	T7	ms	0	--	--
System PWM Off to B/L Power Disable	T8	ms	10	--	--
Backlight Power Off Time	T9	ms	--	10	30
Backlight Off to Signal Disable	T10	ms	200	--	--
Signal Disable to Power Down	T11	ms	0	--	50
VDD Fall Time	T12	ms	--	10	30
Power Off	T13	ms	500	--	--

Optical Characteristics

Items		Symbol	Condition	Min.	Typ.	Max.	Unit	Remark
Viewing angles		θ_T	Center $CR \geq 10$		80	-	Degree.	Note2
		θ_B			80	-		
		θ_L			80	-		
		θ_R			80	-		
Contrast Ratio		CR	$\Theta = 0$	-	600	-	-	Note1, Note3
Response Time		T_{ON}	$25^\circ C$	-	6	8	ms	Note1, Note4
		T_{OFF}		-	20	28		
Chromaticity	White	X_W		-	-	-	-	Note1, Note5
		Y_W		-	-	-	-	
Uniformity		U		-	75	-	%	Note1, Note6
Luminance		L		-	350			Note1, Note7

Test Conditions:

1. IF= 20mA(one channel),the ambient temperature is $25^\circ C$
2. The test systems refer to Note 1 and Note 2.

Note 1:Definition of optical measurement system.

The optical characteristics should be measured in dark room. After 5 minutes operation, the optical properties are measured at the center point of the LCD screen. All input terminals LCD panel must be ground when measuring the center area of the panel.



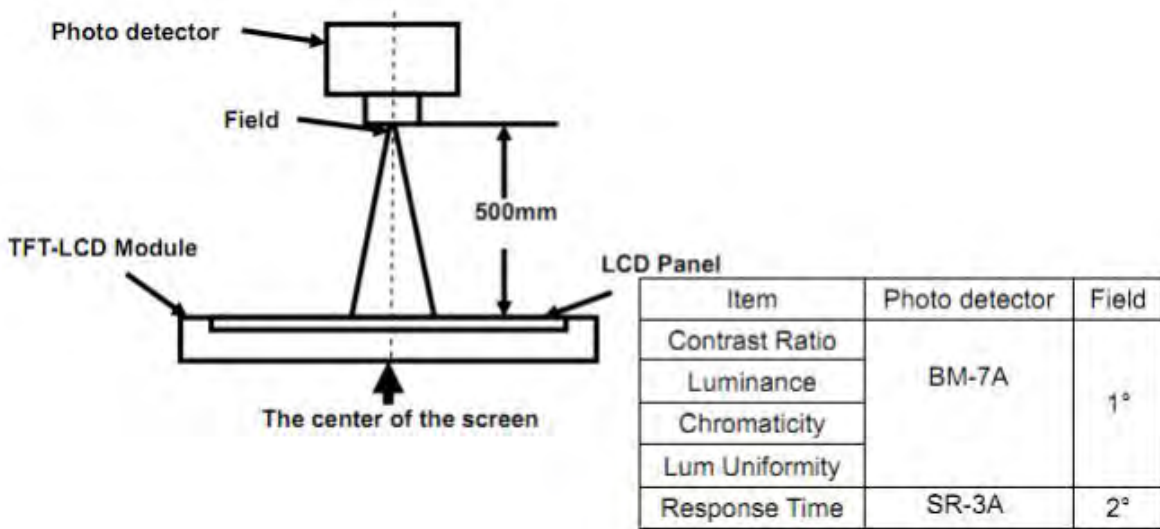

Note 2: Definition of viewing angle range and measurement system.
viewing angle is measured at the center point of the LCD by CONOSCOPE(ergo-80).

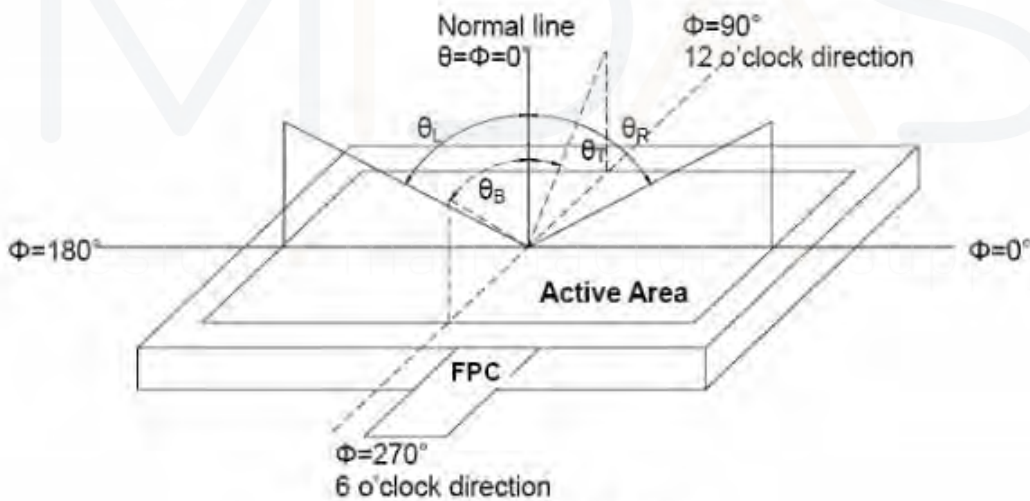

Fig. 1 Definition of viewing angle

Note 3: Definition of contrast ratio

$$\text{Contrast ratio (CR)} = \frac{\text{Luminance measured when LCD is on the "White" state}}{\text{Luminance measured when LCD is on the "Black" state}}$$

Note 4: Definition of Response time

The response time is defined as the LCD optical switching time interval between "White" state and "Black" state. Rise time (TON) is the time between photo detector output intensity changed from 90% to 10%. And fall time (TOFF) is the time between photo detector output intensity changed from 10% to 90%.

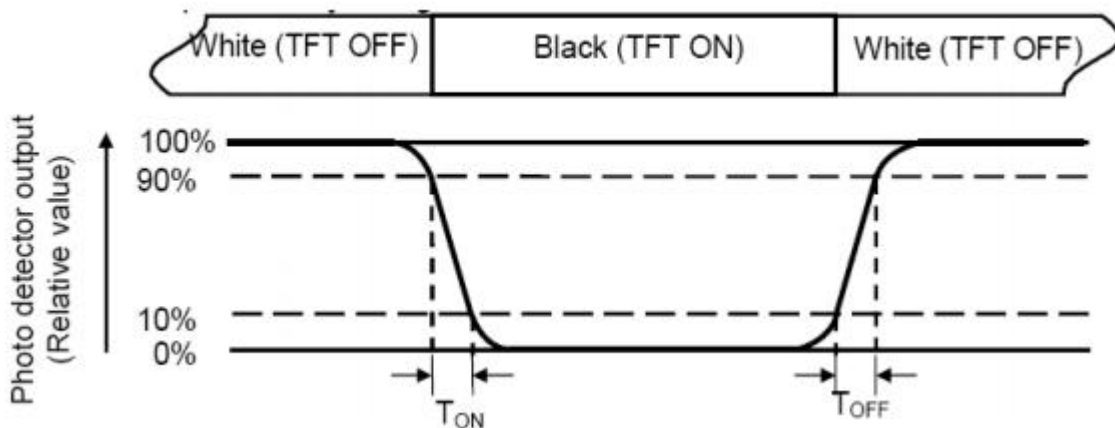

Note 5: Definition of color chromaticity (CIE1931)
 Color coordinates measured at center point of LCD.

Note 6: Definition of Luminance Uniformity

Active area is divided into 9 measuring areas (Refer Fig. 2). Every measuring point is placed at the center of each measuring area.

$$\text{Luminance Uniformity}(U) = L_{\min} / L_{\max} \times 100\%$$

L-----Active area length W----- Active area width

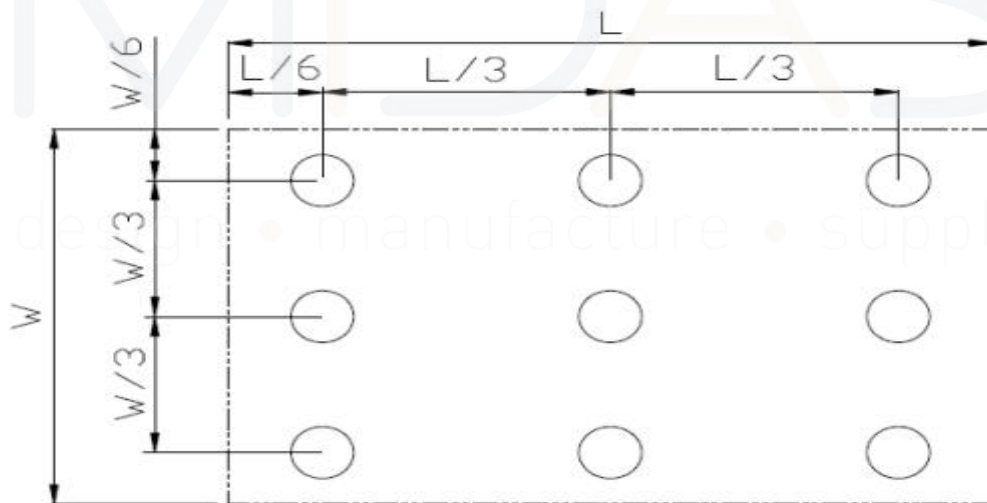

Fig. 2 Definition of uniformity

L_{\max} : The measured maximum luminance of all measurement position.

L_{\min} : The measured minimum luminance of all measurement position.

Note 7: Definition of Luminance :

Measure the luminance of white state at center point.



Environmental / Reliability Tests

No	Test Item	Condition	Remarks
1	High Temperature Opeartion	T _s = +70°C, 240hrs	Note 1 IEC60068-2-2, GB2423. 2-89
2	Low Temperature Opeartion	T _a = -20°C, 240hrs	Note 2 IEC60068-2-1 GB2423.1-89
3	High Temperature Storage	T _a = +80°C, 240hrs	IEC60068-2-2 GB2423. 2-89
4	Low Temperature Storage	T _a = -30°C, 240hrs	IEC60068-2-1 GB/T2423.1-89
5	High Temperature & Humidity Storage	T _a = +60°C, 90% RH max, 160 hours	IEC60068-2-3 GB/T2423.3-2006
6	Thermal Shock (Non-operation)	-30°C 30 min ~ +80°C 30 min Change time: 5min, 30 Cycle	Start with cold temperature,end with high temperature IEC60068-2-14, GB2423.22-87
7	Electro Static Discharge (Opeartion)	C=150pF, R=330 Ω, 5 points/panel Air: ±8KV, 5 times; Contact: ±4KV, 5 times; (Environment: 15°C ~ 35°C, 30% ~ 60%, 86Kpa ~ 106Kpa)	IEC61000-4-2 GB/T17626.2-1998
8	Vibration (Non-operation)	Frequency range: 10~55Hz, Stroke: 1.mm Sweep: 10Hz~55Hz~10Hz 2 hours for each direction of X .Y. Z. (package condition)	IEC60068-2-6 GB/T2423.5-1995
9	Shock (Non-operation)	60G 6ms, ± X, ± Y, ± Z 3 times for each direction	IEC60068-2-27 GB/T2423.5-1995
10	Package Drop Test	Height: 80 cm, 1 corner, 3 edges, 6 surfaces	IEC60068-2-32 GB/T2423.8-1995

Note: 1. T_s is the temperature of panel's surface.
2. T_a is the ambient temperature of sample.



Mechanical Drawing

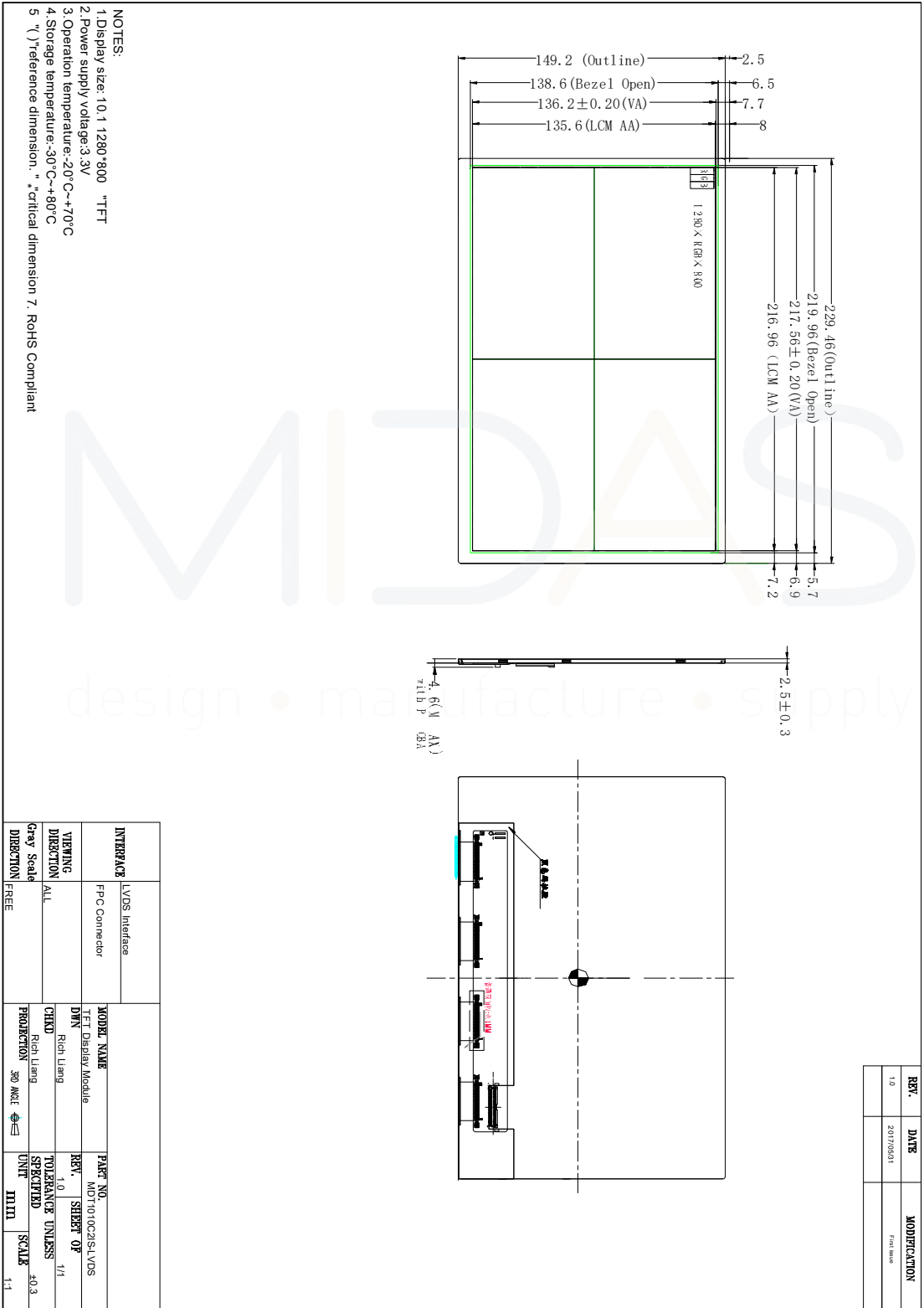

Precautions For Use of LCD modules

1. Handling Precautions

1.1. The display panel is made of glass. Do not subject it to a mechanical shock by dropping it from a high place, etc.

1.2. If the display panel is damaged and the liquid crystal substance inside it leaks out, be sure not to get any in your mouth, if the substance comes into contact with your skin or clothes, promptly wash it off using soap and water.

1.3. Do not apply excessive force to the display surface or the adjoining areas since this may cause the color tone to vary.

1.4. The polarizer covering the display surface of the LCD module is soft and easily scratched. Handle this polarizer carefully.

1.5. If the display surface is contaminated, breathe on the surface and gently wipe it with a soft dry cloth. If still not completely clear, moisten cloth with one of the following solvents:

- Isopropyl alcohol
- Ethyl alcohol

Solvents other than those mentioned above may damage the polarizer. Especially, do not use the following:

- Water
- Ketone
- Aromatic solvents

1.6. Do not attempt to disassemble the LCD Module.

1.7. If the logic circuit power is off, do not apply the input signals.

1.8. To prevent destruction of the elements by static electricity, be careful to maintain an optimum work environment.

1.8.1. Be sure to ground the body when handling the LCD Modules.

1.8.2. Tools required for assembly, such as soldering irons, must be properly ground.

1.8.3. To reduce the amount of static electricity generated, do not conduct assembly and other work under dry conditions.

1.8.4. The LCD Module is coated with a film to protect the display surface. Be care when peeling off this protective film since static electricity may be generated.

2. Storage Precautions

2.1. When storing the LCD modules, avoid exposure to direct sunlight or to the light of fluorescent lamps.

2.2. The LCD modules should be stored under the storage temperature range. If the LCD modules will be stored for a long time, the recommend condition is:

Temperature : 0°C ~ 40°C Relatively humidity: ≤80%

2.3. The LCD modules should be stored in the room without acid, alkali and harmful gas.

3. Transportation Precautions

The LCD modules should be no falling and violent shocking during transportation, and also should avoid excessive press, water, damp and sunshine.

